

KT 30 / 7

SCARRABILE CON SFILLO E RIBALTAMENTO

* CILINDRO DI SPUNTO
VERIN DE AIDE DU BENNAGE
START TIPPING CYLINDER

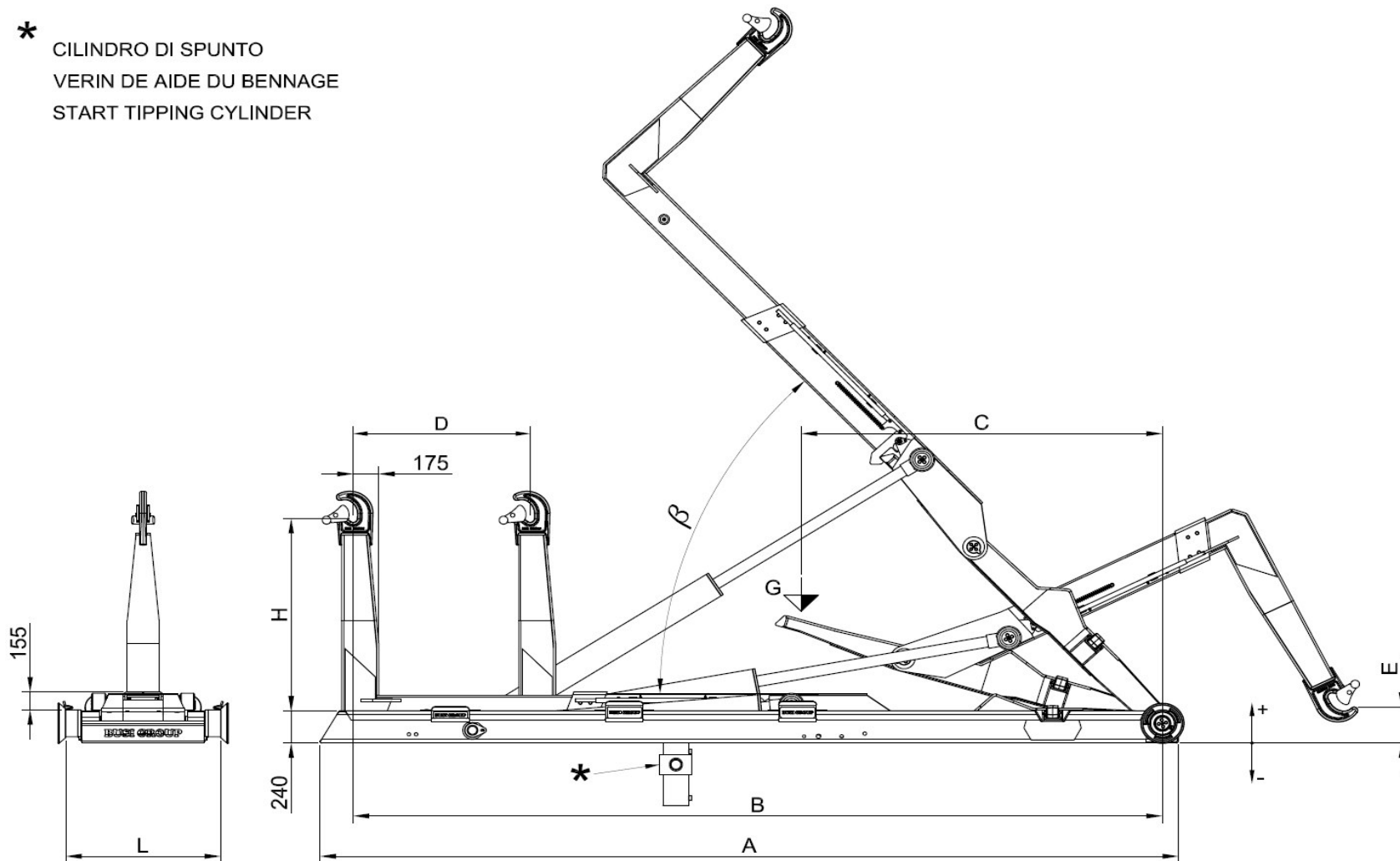

Modèle Equip	PTAC Minimum conseillée	Poids Equip	Angle	Debit conseillée de la pompe	Pression Max	Capacité maximale de charge	Dimensions						Caisson conseillé		
Equipment Model	Minimum GVW recommended	Equip Weight	Angle	Recomm. pump flow	Max Pressure	Maximum loading capacity	Dimensions						Recommended container		
Modello Scarrabile	PTT Minimo consigliato	Peso Scarr.	Angolo	Portata consigliata della pompa	Pressione Max	Capacità massima di carico	Dimensioni						Cassa consigliata		
	TON	Kg	β	Litri / min	Bar	TON	A	B	C	D	H	E	L	MIN	MAX
KT 30 / 67	32	3180	52°	95	340	30	6940	6700	3350	1560	1430 / 1570	170 / 40	1070	5200	7400