

SC 008

SCARRABILE CON SFILLO E RIBALTAMENTO

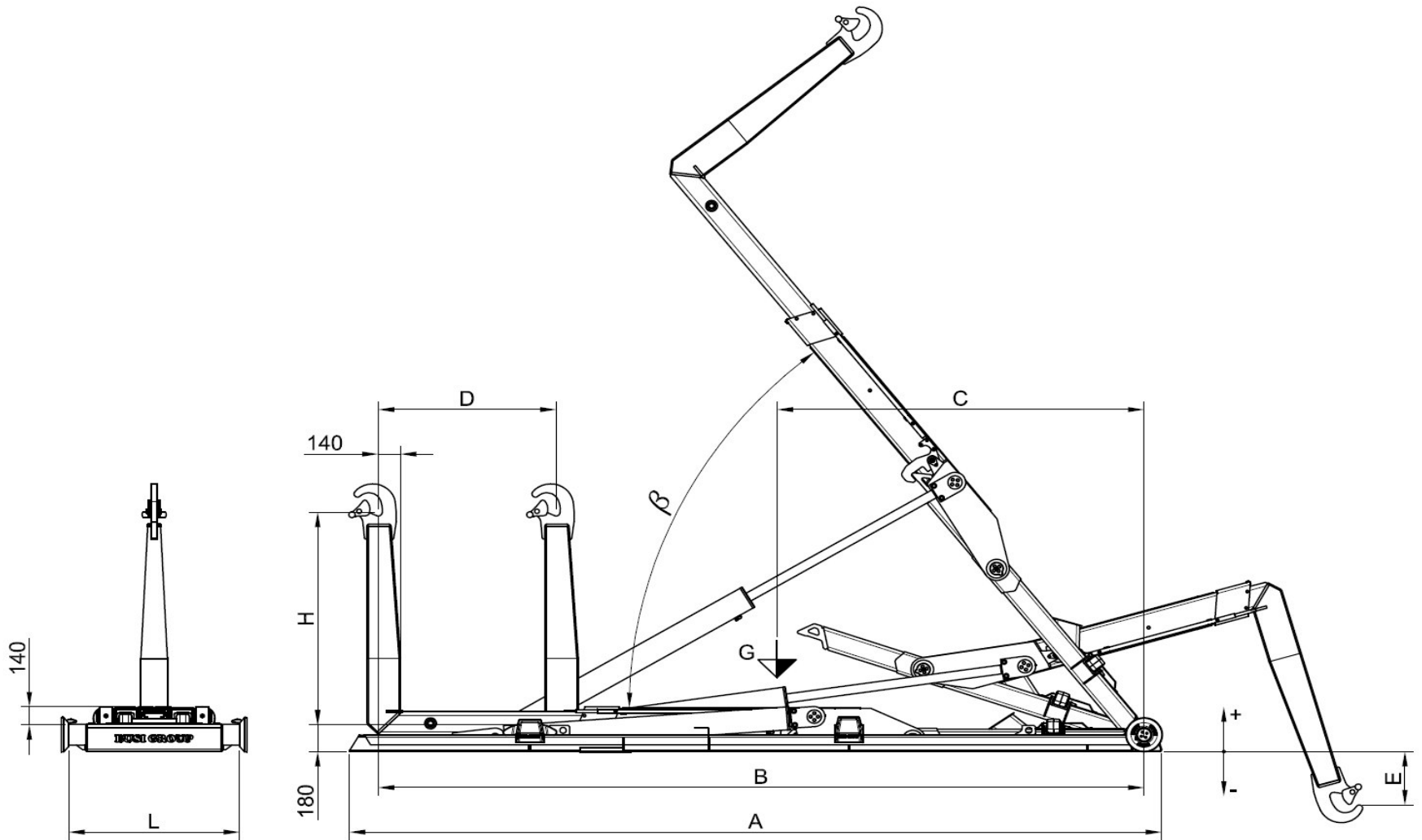

Modèle Equip	PTAC Minimum conseillée	Poids Equip	Angle	Debit conseillée de la pompe	Pression Max	Capacité maximale de charge	Dimensions							Caisson conseillé	
Equipment Model	Minimum GVW recommended	Equip Weight	Angle	Recomm. pump flow	Max Pressure	Maximum loading capacity	Dimensions							Recommended container	
Modello Scarrabile	PTT Minimo consigliato	Peso Scarr.	Angolo	Portata consigliata della pompa	Pressione Max	Capacità massima di carico	Dimensioni							Cassa consigliata	
	TON	Kg	β	Litri / min	Bar	TON	A	B	C	D	H	E	L	MIN	MAX
SC 008 / 36	10	1330	60°	35	340	8	3890	3600	1870	715	900 / 1430	-165 / -685	1070	3000	4000
SC 008 / 38	10	1360	58°	35	340	8	4090	3800	2040	715	900 / 1430	-210 / -740	1070	3200	4200
SC 008 / 40	10	1390	58°	35	340	8	4290	4000	2090	715	900 / 1430	-210 / -740	1070	3400	4400
SC 008 / 42	10	1460	56°	35	340	8	4490	4200	2290	715	900 / 1430	-135 / -665	1070	3600	4600
SC 008 / 44	10	1470	56°	35	340	8	4690	4400	2320	915	900 / 1430	-135 / -665	1070	3600	4800
SC 008 / 46	10	1550	56°	35	340	8	4890	4600	2380	915	900 / 1430	-125 / -655	1070	3800	5000
SC 008 / 48	10	1550	56°	35	340	8	5090	4800	2420	1115	900 / 1430	-125 / -655	1070	3800	5200