

# SC 012

SCARRABILE CON SFILLO E RIBALTAMENTO

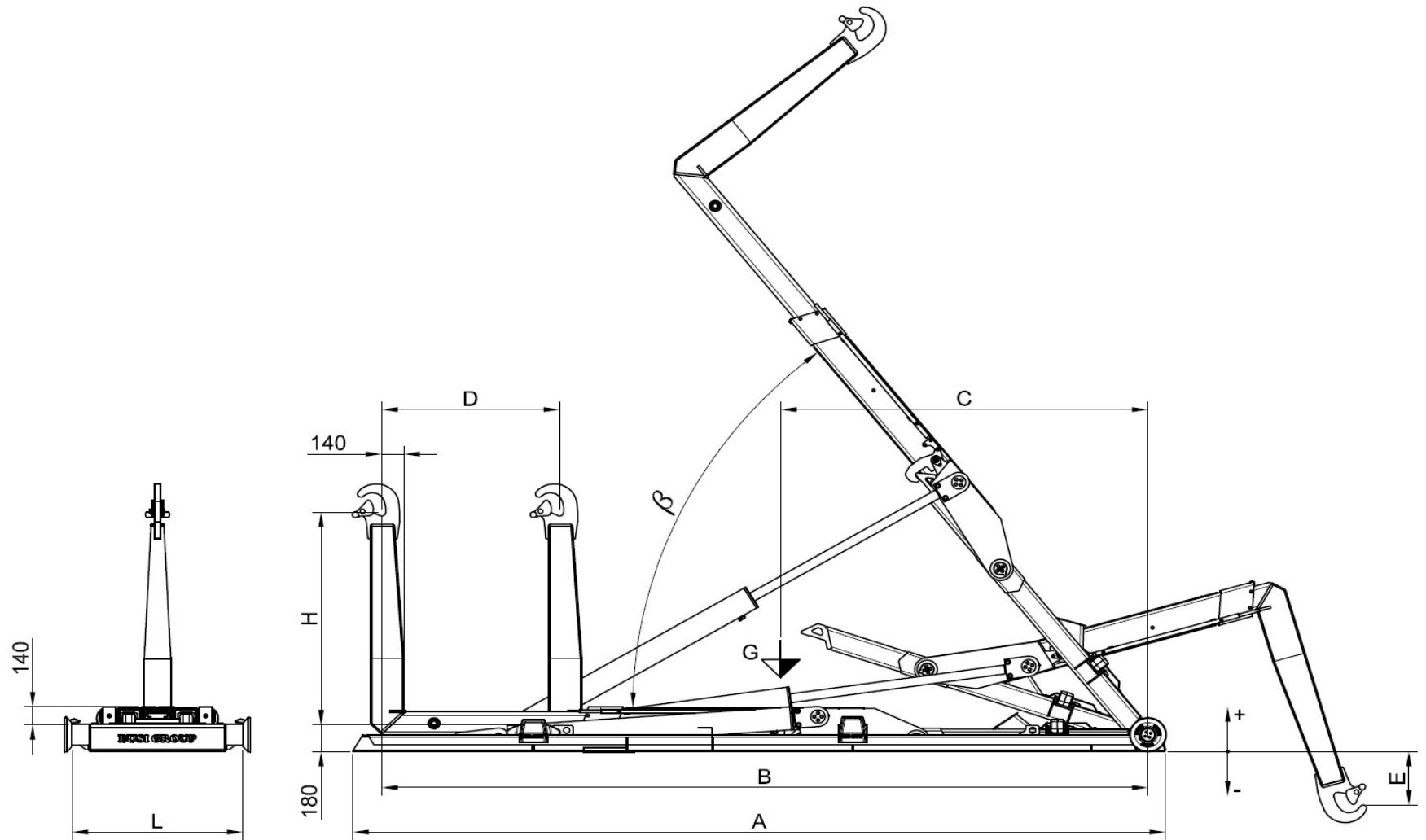

Modèle Equip	PTAC Minimum conseillée	Poids Equip	Angle	Debit conseillée de la pompe	Pression Max	Capacité maximale de charge	Dimensions							Caisson conseillé	
Equipment Model	Minimum GVW recommended	Equip Weight	Angle	Recomm. pump flow	Max Pressure	Maximum loading capacity	Dimensions							Recommended container	
Modello Scarrabile	PTT Minimo consigliato	Peso Scarr.	Angolo	Portata consigliata della pompa	Pressione Max	Capacità massima di carico	Dimensioni							Cassa consigliata	
	TON	Kg	$\beta$	Litri / min	Bar	TON	A	B	C	D	H	E	L	MIN	MAX
SC 012 / 42	13,5	1650	56°	45	340	12	4490	4200	2340	715	900 / 1430	-135 / -665	1070	3600	4700
SC 012 / 44	13,5	1660	56°	45	340	12	4690	4400	2370	915	900 / 1430	-135 / -665	1070	3600	4900
SC 012 / 46	13,5	1730	56°	45	340	12	4890	4600	2430	915	900 / 1430	-125 / -655	1070	3800	5100
SC 012 / 48	13,5	1740	56°	45	340	12	5090	4800	2460	1115	900 / 1430	-125 / -655	1070	3800	5300
SC 012 / 50	13,5	1850	54°	45	340	12	5290	5000	2770	915	900 / 1430	-80 / -605	1070	4200	5500
SC 012 / 52	13,5	1860	54°	45	340	12	5490	5200	2820	1115	900 / 1430	-80 / -605	1070	4200	5700