

SC 018/6

SCARRABILE CON SFILLO E RIBALTAMENTO

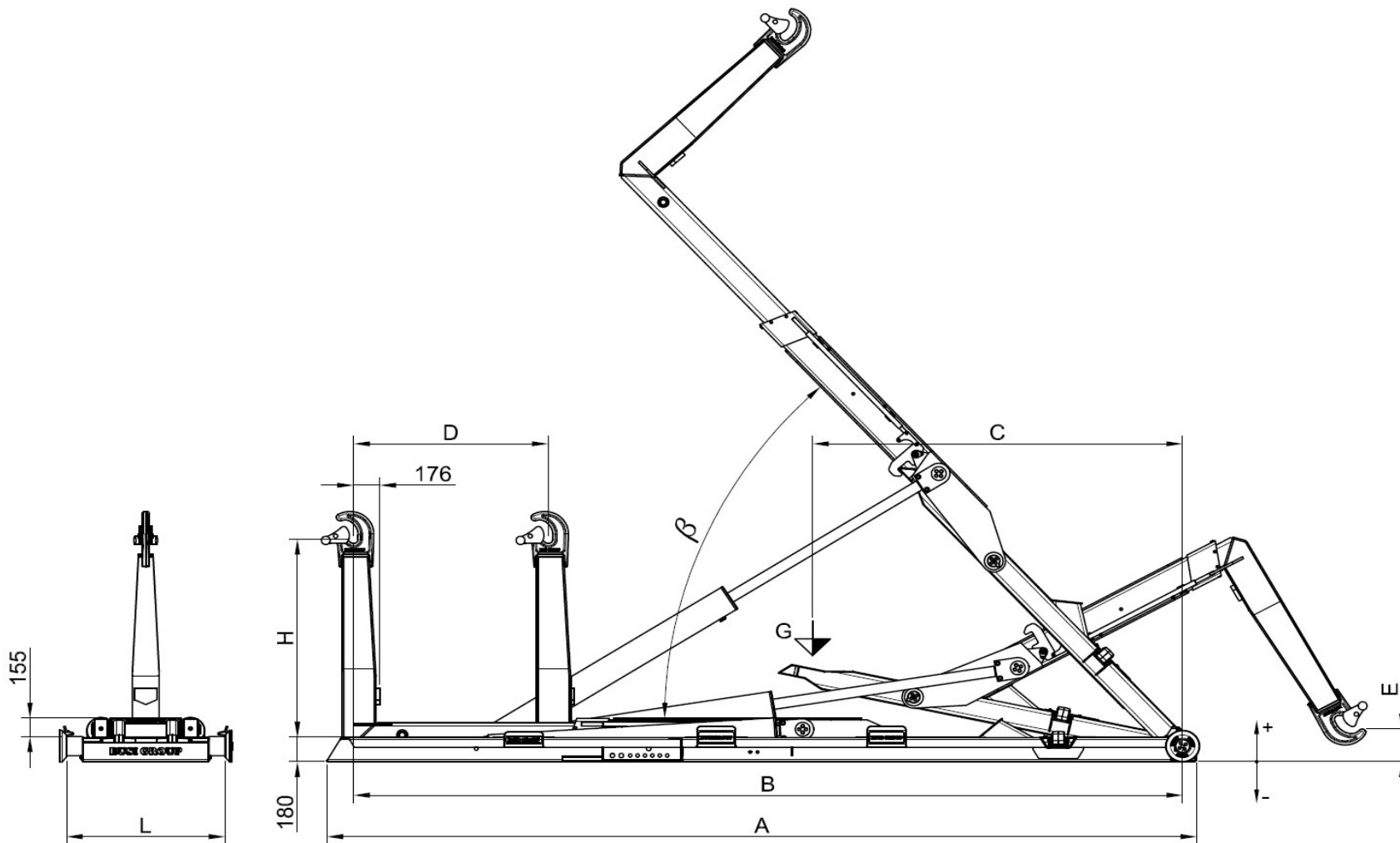

Modèle Equip	PTAC Minimum conseillée	Poids Equip	Angle	Debit conseillée de la pompe	Pression Max	Capacité maximale de charge	Dimensions						Caisson conseillé		
Equipment Model	Minimum GWV recommended	Equip Weight	Angle	Recomm. pump flow	Max Pressure	Maximum loading capacity	Dimensions						Recommended container		
Modello Scarrabile	PTT Minimo consigliato	Peso Scarr.	Angolo	Portata consigliata della pompa	Pressione Max	Capacità massima di carico	Dimensioni						Cassa consigliata		
	TON	Kg	β	Litri / min	Bar	TON	A	B	C	D	H	E	L	MIN	MAX
SC 018 / 42	18	1940	58°	60	340	18	4525	4200	2760	915	1430 / 1570	-165 / -290	1070	3400	4800
SC 018 / 44	18	1970	54°	60	340	18	4725	4400	2900	915	1430 / 1570	-80 / -205	1070	3600	5000
SC 018 / 46	18	2010	54°	60	340	18	4875	4600	2950	915	1430 / 1570	10 / -115	1070	3800	5200
SC 018 / 48	18	2020	54°	60	340	18	5075	4800	3000	1115	1430 / 1570	10 / -115	1070	3800	5400
SC 018 / 50	18	2120	52°	60	340	18	5475	5000	3100	915	1430 / 1570	-95 / -230	1070	4200	5600
SC 018 / 52	18	2120	52°	60	340	18	5475	5200	3150	1115	1430 / 1570	-95 / -230	1070	4200	5800
SC 018 / 54	18	2170	52°	60	340	18	5675	5400	3200	1115	1430 / 1570	-45 / -175	1070	4400	6000
SC 018 / 56	18	2180	52°	60	340	18	5875	5600	3250	1315	1430 / 1570	-45 / -175	1070	4400	6200