

# SC 266

SCARRABILE CON SFILLO E RIBALTAMENTO

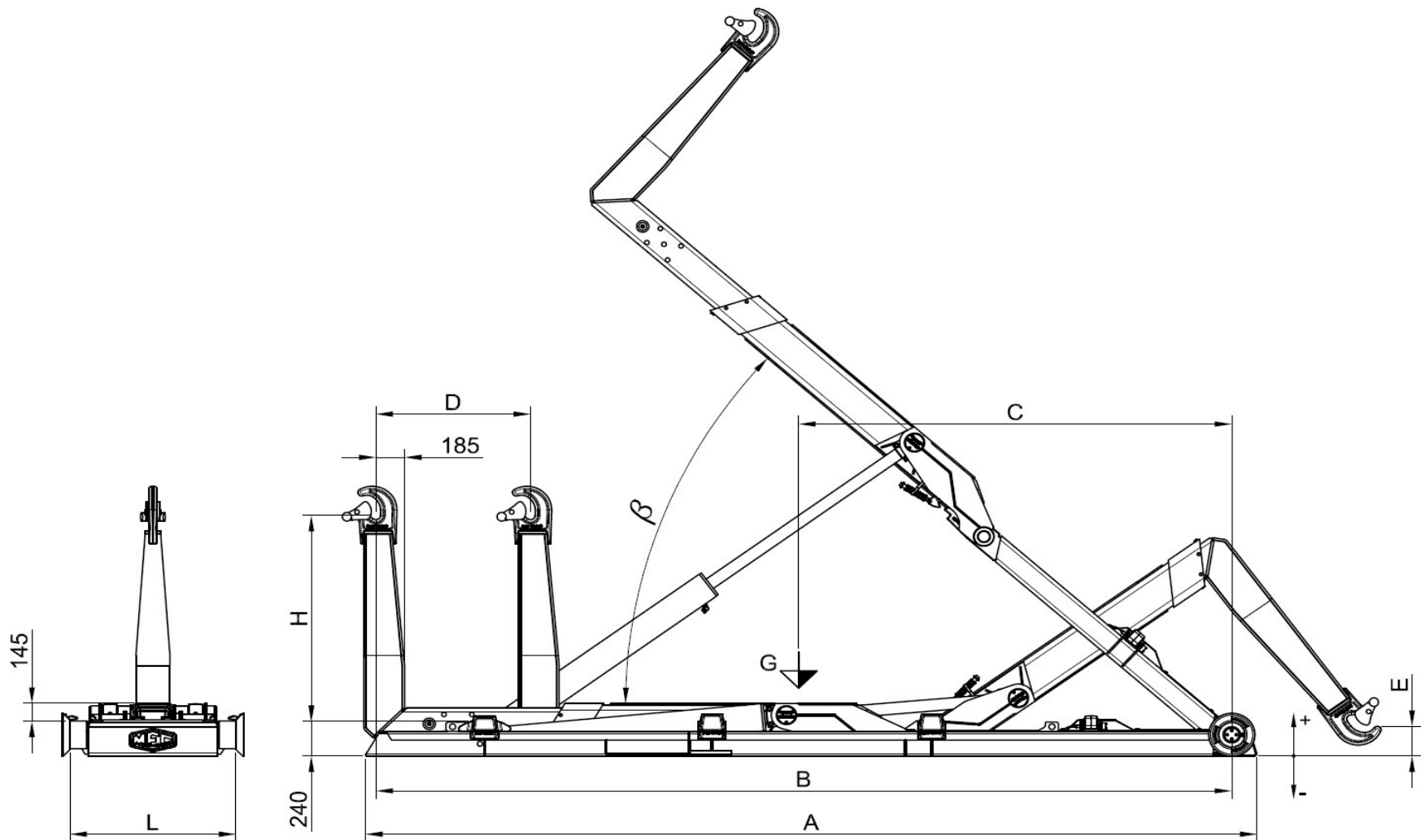

Modèle Equip	PTAC Minimum conseillée	Poids Equip	Angle	Debit conseillée de la pompe	Pression Max	Capacité maximale de charge	Dimensions							Caisson conseillé	
							Dimensions								
Equipment Model	Minimum GVW recommended	Equip Weight	Angle	Recomm. pump flow	Max Pressure	Maximum loading capacity	Dimensions							Recommended container	
Modello Scarrabile	PTT Minimo consigliato	Peso Scarr.	Angolo	Portata consigliata della pompa	Pressione Max	Capacità massima di carico	Dimensioni							Cassa consigliata	
	TON	Kg	β	Litri / min	Bar	TON	A	B	C	D	H	E	L	MIN	MAX
SC 266 XC	26	2380	54°	80	340	24	4760	4530	2880	1000	1430 / 1570	100 / -30	1070	3600	5200
SC 266 C	26	2420	51°	80	340	24	4960	4730	2930	1000	1430 / 1570	100 / -30	1070	3800	5400
SC 266 NC	26	2460	48°	80	340	24	5160	4930	2980	1000	1430 / 1570	100 / -30	1070	4000	5600
SC 266 N	26	2490	48°	80	340	24	5360	5130	3050	1000	1430 / 1570	220 / 90	1070	4200	5800
SC 266 NL	26	2530	45°	80	340	24	5560	5330	3100	1000	1430 / 1570	220 / 90	1070	4400	6000
SC 266 L	26	2580	42°	80	340	24	5760	5530	3150	1000	1430 / 1570	220 / 90	1070	4600	6200
SC 266 XL	26	2620	42°	80	340	24	5860	5630	3180	1100	1430 / 1570	220 / 90	1070	4600	6300