

SC 267

SCARRABILE CON SFILLO E RIBALTAMENTO

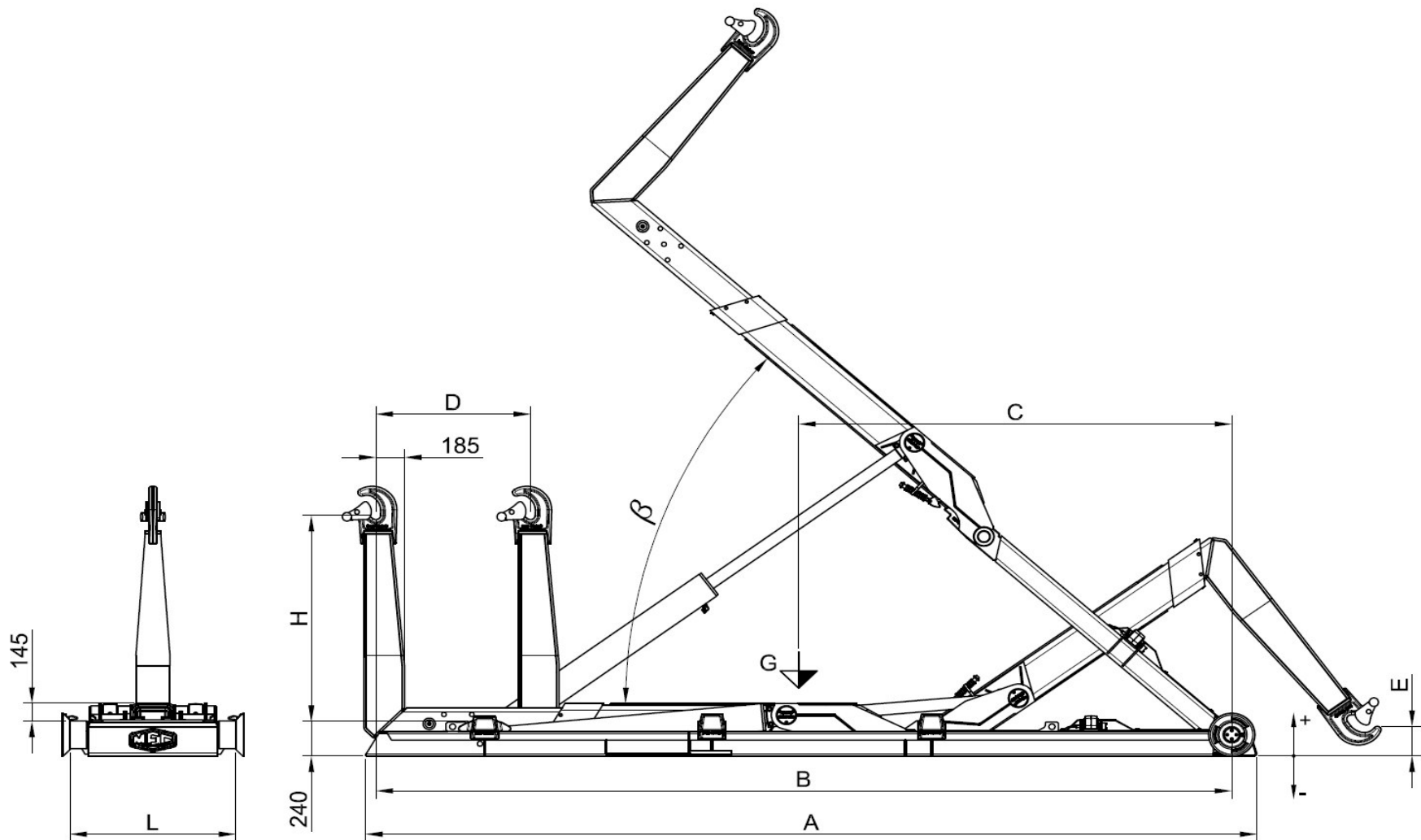

Modèle Equip	PTAC Minimum conseillée	Poids Equip	Angle	Debit conseillée de la pompe	Pression Max	Capacité maximale de charge	Dimensions						Caisson conseillé		
Equipment Model	Minimum GVW recommended	Equip Weight	Angle	Recomm. pump flow	Max Pressure	Maximum loading capacity	Dimensions						Recommended container		
Modello Scarrabile	PTT Minimo consigliato	Peso Scarr.	Angolo	Portata consigliata della pompa	Pressione Max	Capacità massima di carico	Dimensioni						Cassa consigliata		
	TON	Kg	β	Litri / min	Bar	TON	A	B	C	D	H	E	L	MIN	MAX
SC 267 C	26	2780	54°	90	340	24	6005	5760	3200	1300	1430 / 1570	20 / -120	1070	4600	6400
SC 267 NC	26	2820	51°	90	340	24	6205	5960	3310	1300	1430 / 1570	20 / -120	1070	4800	6600
SC 267 N	26	2860	51°	90	340	24	6405	6160	3420	1300	1430 / 1570	120 / -15	1070	5000	6800
SC 267 NL	26	2900	48°	90	340	24	6595	6350	3530	1300	1430 / 1570	120 / -15	1070	5200	7000
SC 267 L	26	2940	46°	90	340	24	6795	6550	3640	1300	1430 / 1570	120 / -15	1070	5400	7200