

SC 307

SCARRABILE CON SFILLO E RIBALTAMENTO

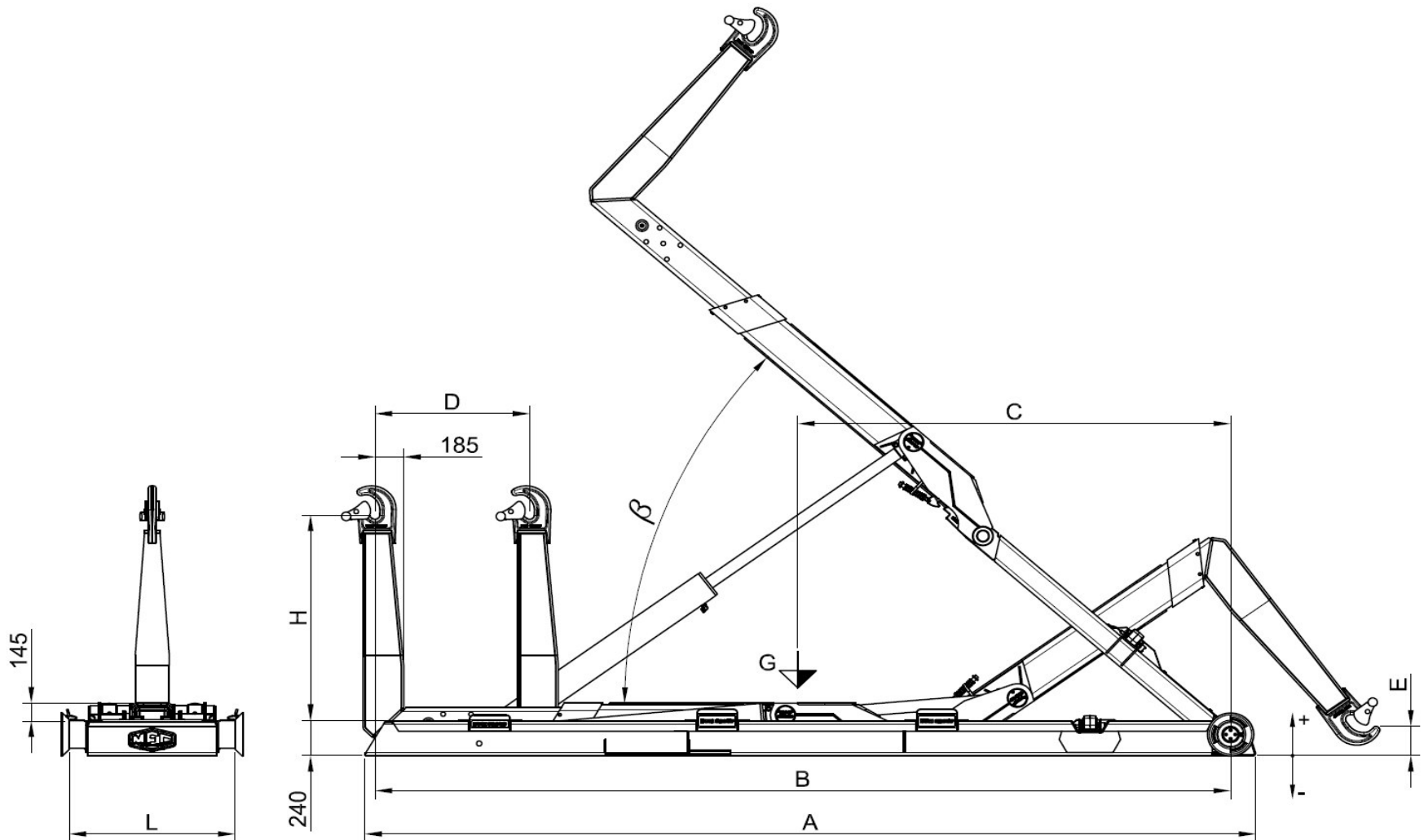

Modèle Equip	PTAC Minimum conseillée	Poids Equip	Angle	Debit conseillée de la pompe	Pression Max	Capacité maximale de charge	Dimensions							Caisson conseillé	
Equipment Model	Minimum GVW recommended	Equip Weight	Angle	Recomm. pump flow	Max Pressure	Maximum loading capacity	Dimensions							Recommended container	
Modello Scarrabile	PTT Minimo consigliato	Peso Scarr.	Angolo	Portata consigliata della pompa	Pressione Max	Capacità massima di carico	Dimensioni							Cassa consigliata	
	TON	Kg	β	Litri / min	Bar	TON	A	B	C	D	H	E	L	MIN	MAX
SC 307 C	32	2980	54°	95	340	30	6005	5760	3200	1300	1430 / 1570	20 / -120	1070	4600	6400
SC 307 NC	32	3020	51°	95	340	30	6205	5960	3310	1300	1430 / 1570	20 / -120	1070	4800	6600
SC 307 N	32	3060	51°	95	340	30	6405	6160	3420	1300	1430 / 1570	120 / -15	1070	5000	6800
SC 307 NL	32	3100	48°	95	340	30	6595	6350	3530	1300	1430 / 1570	120 / -15	1070	5200	7000
SC 307 L	32	3140	46°	95	340	30	6795	6550	3640	1300	1430 / 1570	120 / -15	1070	5400	7200