

SCK 206

SCARRABILE CON SFILO, RIBALTAMENTO E ARTICOLAZIONE

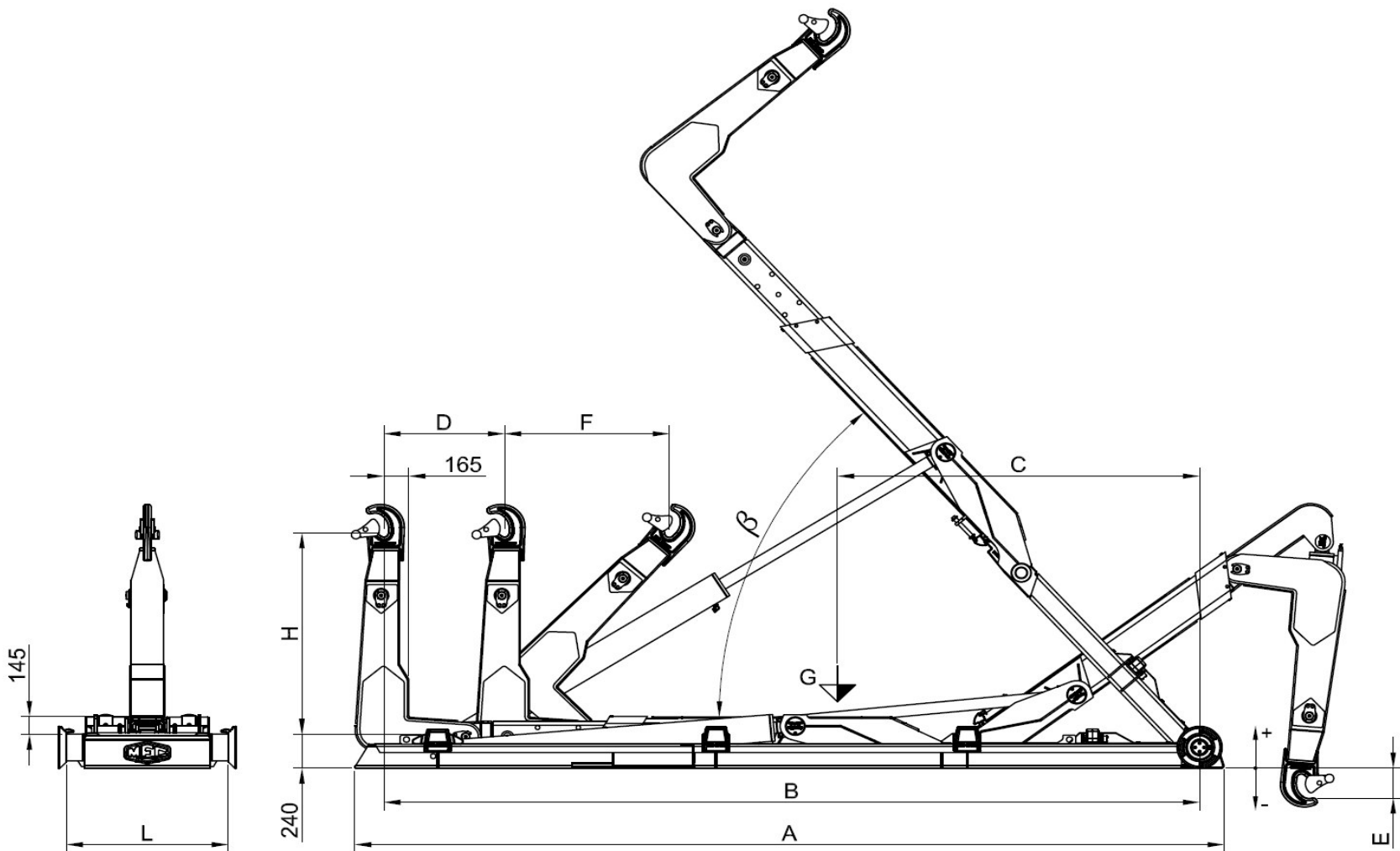

| Modèle Equip | PTAC Minimum conseillée | Poids Equip | Angle | Debit conseillée de la pompe | Pression Max | Capacité maximale de charge | Dimensions | | | | | | | | Caisson conseillé | |
|--------------------|-------------------------|--------------|----------|---------------------------------|---------------|-----------------------------|------------|----------|----------|----------|-------------|-------------|-------------|----------|-----------------------|------------|
| Equipment Model | Minimum GVW recommended | Equip Weight | Angle | Recomm. pump flow | Max Pressure | Maximum loading capacity | Dimensions | | | | | | | | Recommended container | |
| Modello Scarrabile | PTT Minimo consigliato | Peso Scarr. | Angolo | Portata consigliata della pompa | Pressione Max | Capacità massima di carico | Dimensioni | | | | | | | | Cassa consigliata | |
| | TON | Kg | β | Litri / min | Bar | TON | A | B | C | D | H | E | F | L | MIN | MAX |
| SCK 206 NC | 26 | 2630 | 58° | 70 | 340 | 20 | 5160 | 4810 | 2770 | 800 | 1430 / 1570 | -360 / -500 | 1090 / 1180 | 1070 | 3000 | 5500 |
| SCK 206 N | 26 | 2670 | 54° | 70 | 340 | 20 | 5360 | 5010 | 2870 | 800 | 1430 / 1570 | -360 / -500 | 1090 / 1180 | 1070 | 3200 | 5700 |
| SCK 206 NL | 26 | 2730 | 59° | 70 | 340 | 20 | 5560 | 5210 | 3020 | 800 | 1430 / 1570 | -460 / -600 | 1090 / 1180 | 1070 | 3400 | 5900 |
| SCK 206 L | 26 | 2770 | 54° | 70 | 340 | 20 | 5760 | 5410 | 3110 | 800 | 1430 / 1570 | -460 / -600 | 1090 / 1180 | 1070 | 3600 | 6100 |
| SCK 206 XL | 26 | 2810 | 54° | 70 | 340 | 20 | 5960 | 5610 | 3200 | 1000 | 1430 / 1570 | -460 / -600 | 1090 / 1180 | 1070 | 3600 | 6300 |
| SCK 206 XXL | 26 | 2850 | 54° | 70 | 340 | 20 | 6195 | 5845 | 3300 | 1235 | 1430 / 1570 | -460 / -600 | 1090 / 1180 | 1070 | 3600 | 6500 |